

TOP VIEW

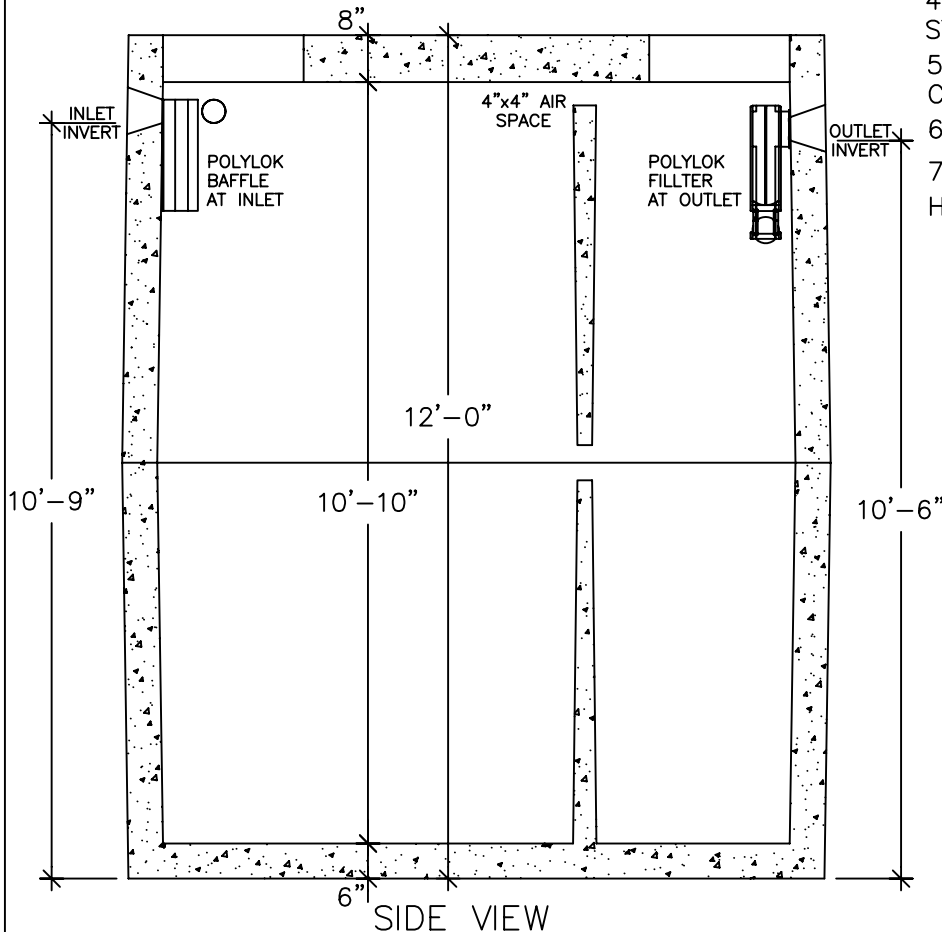

SIDE VIEW

# 4500 GALLON HS-20 SEPTIC TANK

TANK DESIGN SPECIFICATION  
CONFORMS TO LATEST:  
ASTM DESIGNATION C1227

NOTES:

1. JOINT SEALANT IS BUTYL RUBBER MASTIC TYPE SEAL THAT CONFORMS TO LATEST AASHTO SPECIFICATION M-198. MEETS FEDERAL SPECIFICATION SS-S-0021(210-A).
2. PIPE INLET AND OUTLET LOCATIONS HAVE POLYLOK II PIPE SEALS.
3. REINFORCING STEEL DEFORMED BARS CONFORM TO LATEST ASTM SPECIFICATION A615.
4. CONCRETE COMPRESSIVE STRENGTH- 4000 PSI AT 28 DAYS.
5. METHOD OF MANUFACTURE: WET CAST.
6. SECTIONS ARE MONOLITHIC.
7. THE TANK IS DESIGNED FOR HS-20 LOADING w/18" OF SOIL COVER.

WEIGHT CHART

PRODUCT	APPROX WEIGHT
TANK	44000 LBS.

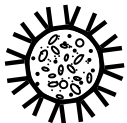

**UNITED CONCRETE PRODUCTS INC.**

173 CHURCH STREET  
YALESVILLE, CT 06492

TEL. 800 234-3119  
(203) 269-3119

FAX. (203) 265-4941