

1250 GALLON HS-20 GREASE TRAP

TANK DESIGN SPECIFICATIONS
CONFORMS TO LATEST:
ASTM DESIGNATION C913

NOTES:

1. JOINT SEALANT IS BUTYL RUBBER MASTIC TYPE SEAL THAT CONFORMS TO LATEST AASHTO SPECIFICATION M-198. MEETS FEDERAL SPECIFICATION SS-S-0021(210-A).
2. PIPE INLET AND OUTLET LOCATIONS HAVE POLYLOK II PIPE SEALS, TYPICAL. CUSTOM KNOCKOUTS CAN BE CAST ON REQUEST.
3. WHEN SPECIFIED THE TANK EXTERIOR IS COATED WITH BAY OIL, "EBONY" OR EQUAL.
4. REINFORCING STEEL DEFORMED BARS CONFORM TO LATEST ASTM SPECIFICATION A615.
5. CONCRETE COMPRESSIVE STRENGTH- 4000 PSI AT 28 DAYS.
6. METHOD OF MANUFACTURE: WET CAST.
7. BASE SECTION IS MONOLITHIC.
8. THE CHAMBER IS DESIGNED FOR HS-20 LOADING w/18" OF SOIL COVER.

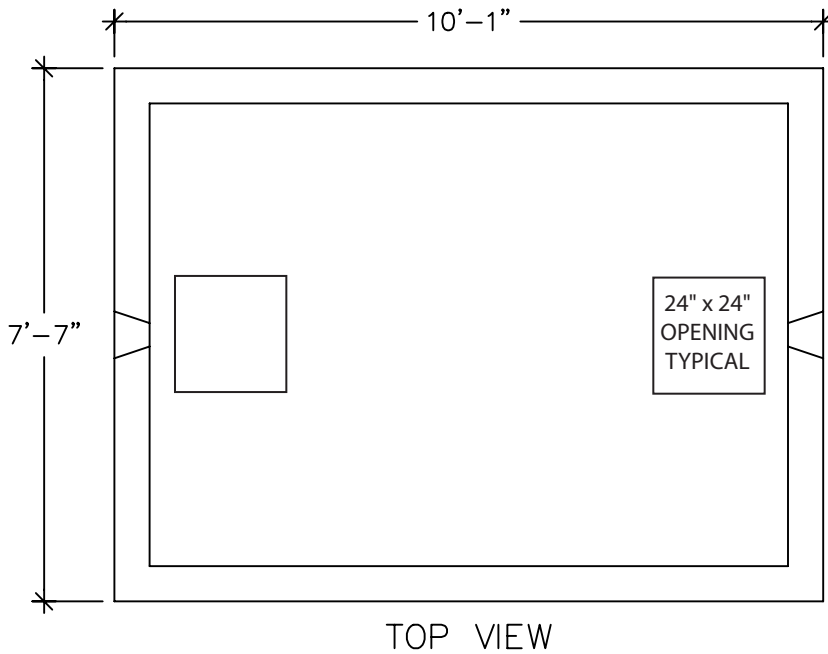

WEIGHT CHART

PRODUCT	APPROX WEIGHT
TANK	22000 LBS.

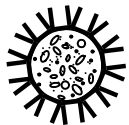
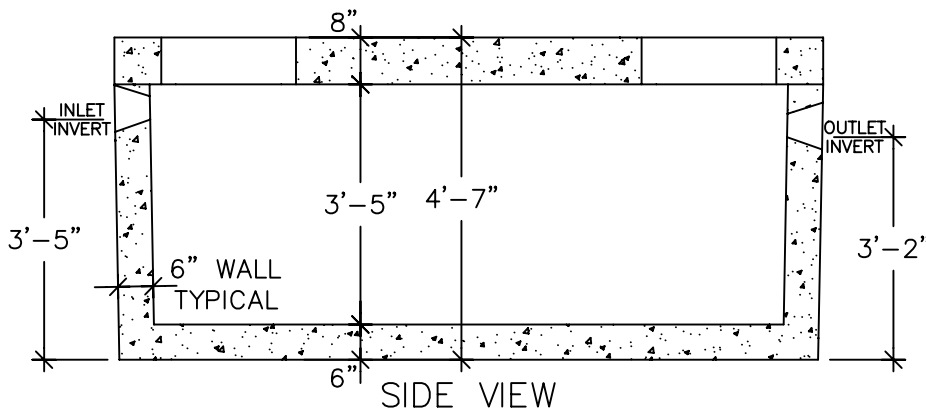

UNITED CONCRETE PRODUCTS INC.

173 CHURCH STREET
YALESVILLE, CT 06492

TEL. 800 234-3119
(203) 269-3119

FAX. (203) 265-4941