

Precast Concrete CURB

Precast concrete curbing is available in two types:

CONCRETE CURBING:

20" H with squared edge finish

STRAIGHT DIMENSIONS:

Concrete Curbing:

20" H x 6" W (top) x 7" W (base)

90 Degree inside and outside corners available

CONCRETE PARK CURBING:

18" H with beveled edge finish.

STRAIGHT DIMENSIONS:

Concrete Park Curbing:

18" H x 2-7/8" W (top)x7" W (base).

Both types meet Connecticut DOT specifications.

STANDARD FEATURES:

Dowel pin hole: 1" dia. X4" depth.
Standard lengths: 8', 6', 5', 4' and 3'

Six concrete reasons to choose Precast Curbing from United Concrete Products

1. Durable

With the proven life expectancy of concrete, precast curbing has the durability required to withstand harsh New England winters without deteriorating in the summer sun.

2. Good-looking

Clean lines and quality finishes give precast concrete curbing the esthetic edge. Concrete's proven resistance to abrasion means curbing that wears beautifully - year after year. No cast-in-place substitute could possibly measure up.

3. Easily installed

Precast concrete curbing installs smoothly, and is easy to replace or reconfigure. Our wide selection of various length straights, radii, and transition ends offer flexibility not only during the initial installation, but throughout the life-time of your project.

4. Quality assurance

Precast concrete curb means assurance of the highest quality concrete plus computer controlled consistency and all of which is unavailable in any cast-in-place substitute.

5. Readily available

Our modern manufacturing facilities can usually turn your order around in days. Because all segments are shipped according to your plans, you'll avoid costly installation delays.

6. Cost-effective

Precast concrete curbing offers excellence with economy. You'll enjoy esthetics and permanence at much lower prices than granite. The long life durability of precast curb offers an advantage over bituminous and cast-in-place concrete curbing. The result: long-term savings in time and money.

Specifications:

1. Concrete strength 5,000 psi
2. Weight 135 lbs./LF
3. 5 - 7% air entrainment
4. Manufactured to Connecticut DOT specifications
5. Top and face are sprayed with Connecticut DOT approved salt protector
6. 1pc 6" long #5 rebar - connecting pins



United Concrete Products, Inc.
173 Church St
Yalesville, CT 06492

Tel: 203-269-3119
800-234-3119
Fax: 203-265-4941

Email: info@unitedconcrete.com
Web: www.unitedconcrete.com

Concrete Park Curb

18" H with beveled edge finish.

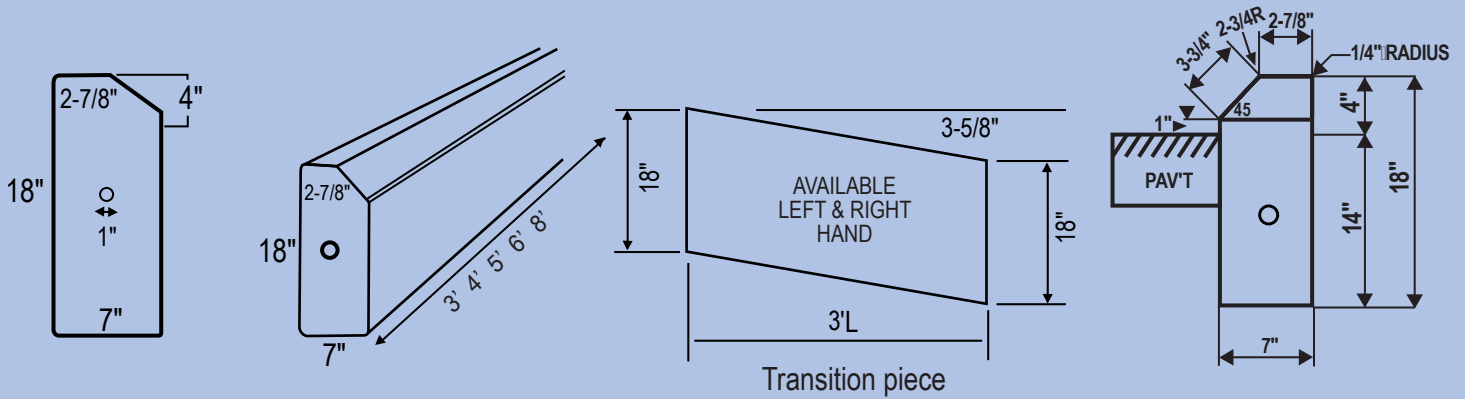

Concrete Curb

20" H with squared edge finish.

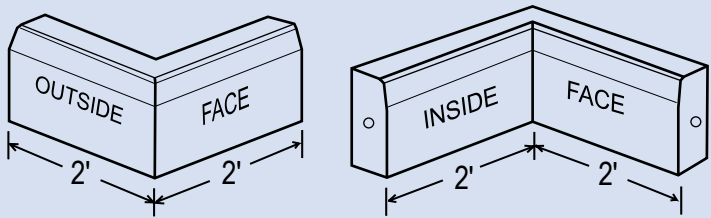
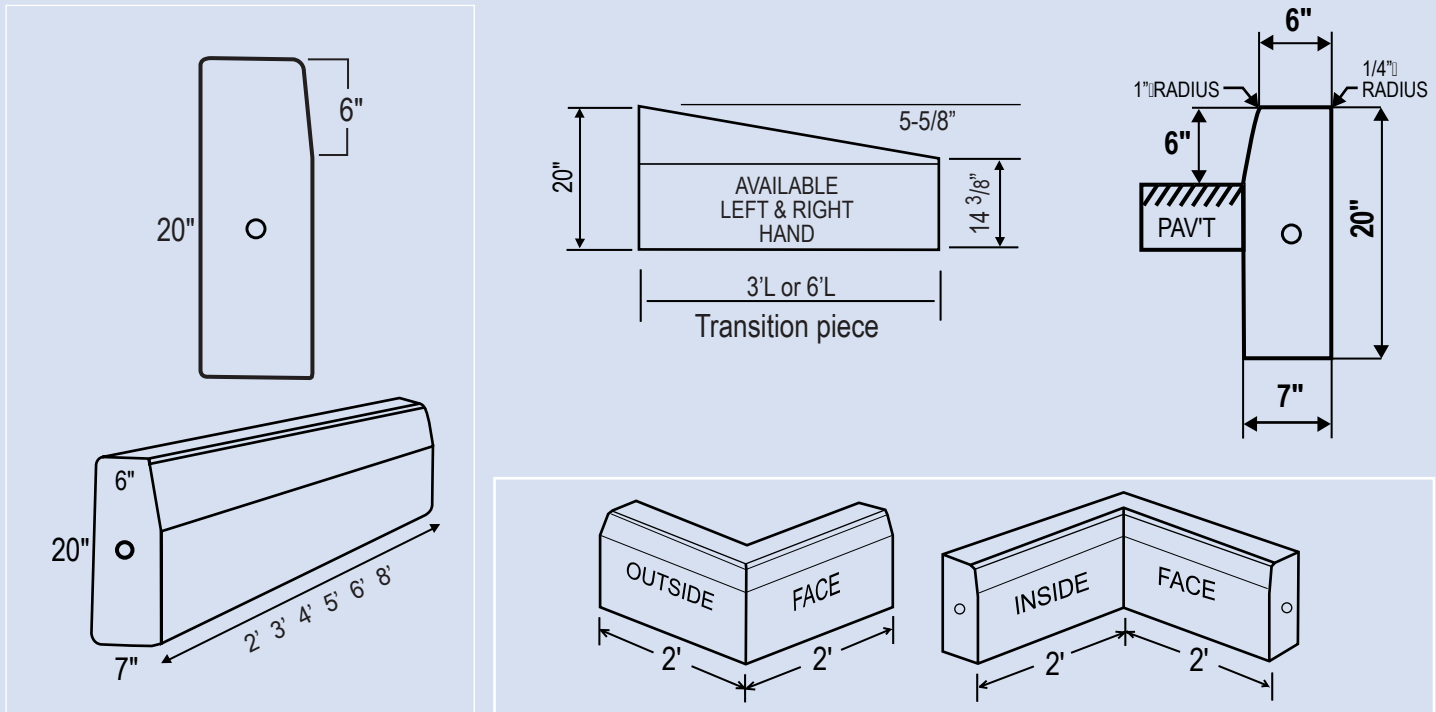

NUMBER OF PIECES TO MAKE A CIRCLE

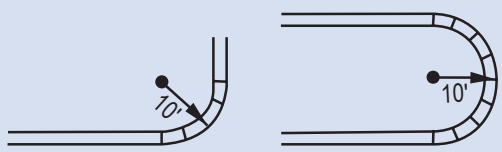

Number of pieces to make a circle: **Concrete Park Curb**

| Radius- Park Curb | 3' | 5' | 10' | 15' | 20' | 25' | 30' | 35' |
|-------------------|-------|-------|--------|--------|--------|--------|--------|--------|
| 4' long pieces | 4 pcs | 8 pcs | 16 pcs | 24 pcs | 32 pcs | 40 pcs | 48 pcs | 56 pcs |

Number of pieces to make a circle: **Concrete Curb**

| Radius- Concrete Curb | 2' | 3' | 5' | 10' | 15' | 20' | 25' | 30' | 35' | 40' | 50' |
|-----------------------|-------|-------|-------|--------|--------|--------|--------|--------|--------|--------|--------|
| 4' long pieces | 4 pcs | 4 pcs | 8 pcs | 16 pcs | 24 pcs | | | | | | |
| 8' long pieces | | | | | | 16 pcs | 20 pcs | 24 pcs | 28 pcs | 32 pcs | 40 pcs |