

EVERWALL®



Retaining Wall System...Incredibly Simple

Combining today's high tech engineering with superior performance of precast concrete, we can now offer an attractive, rugged, low cost retaining wall system.

Ease of installation and minimal space utilization makes Everwall the perfect solution for a wide variety of retaining wall needs.

The unique **Everwall®** design eliminates the need for poured in place concrete footings*. This greatly reduces site preparation time and allows for all weather construction. The functional "drawer" shaped units stack easily and require only 4' to 6' of space for installation. The back of each section is open, which makes backfilling easy and the assembly of an economical and appealing wall fast and hassle free.

In addition, the large 40 sq.ft. (10' x 4'), surface area of each unit considerably reduces crane time and construction costs.

Wall sections can be stacked vertically or in a batter... in straight wall configuration or on a radius. This versatility makes **Everwall®** the obvious solution to your retaining wall needs.

Everwall® is incredibly simple.

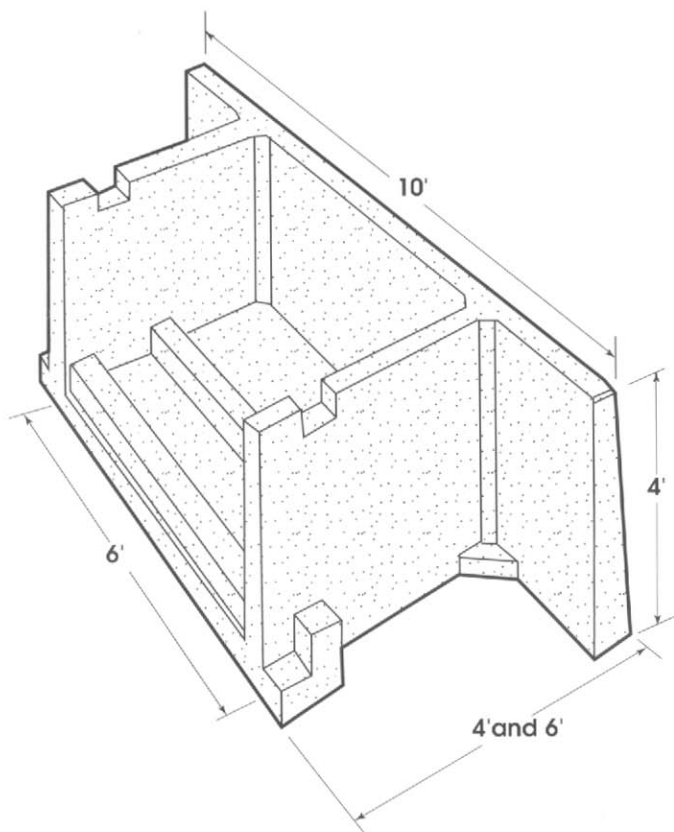

* A base of 1/2" crushed stone is generally recommended. A poured concrete footing may be necessary if unstable ground conditions exist. Consult our engineering department for further information.

APPLICATIONS FOR HIGH WALLS

Everwall® can be used for retaining walls with height greater than 20', with the addition of geotextile reinforcing tied to the Everwall® units.

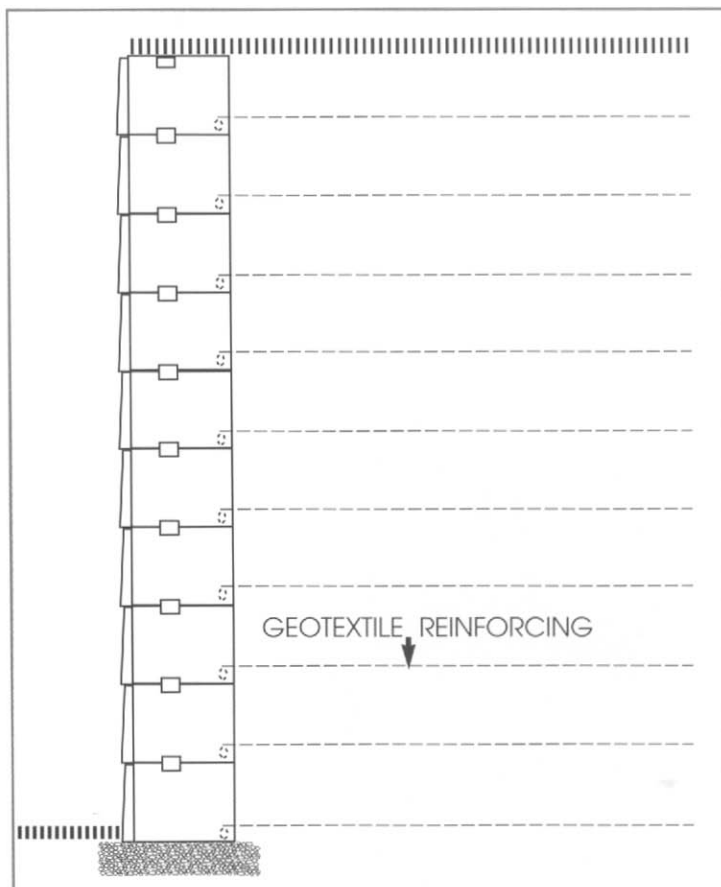

EVERWALL®



VERTICAL INSTALLATION

Face Flush

Offset to Back

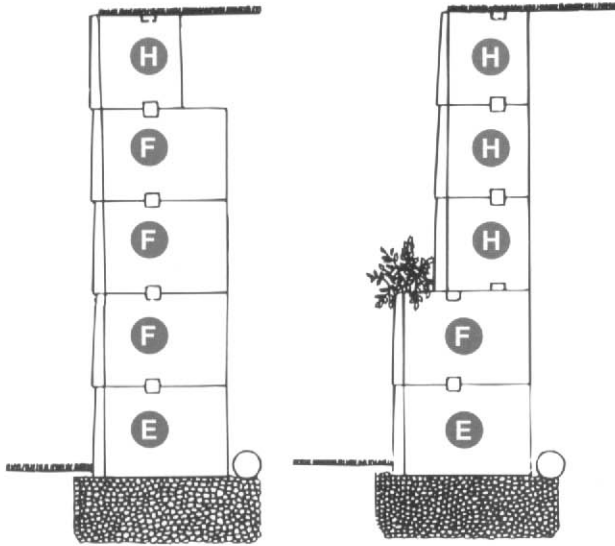

BATTERED INSTALLATION

Face Flush

Offset to Back

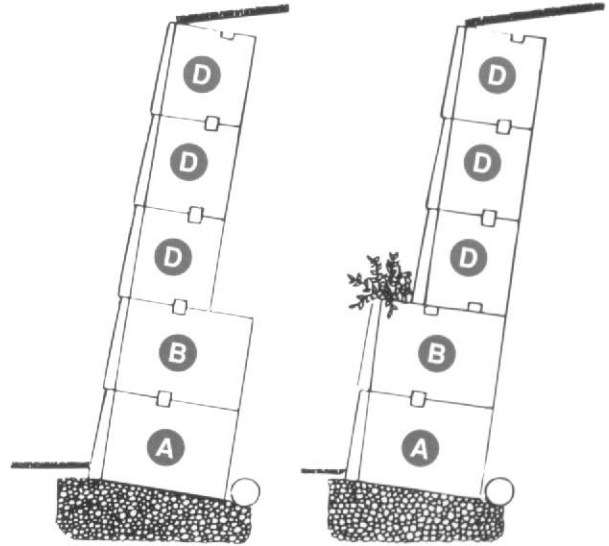

TYPICAL INSTALLATION
(Rear View)

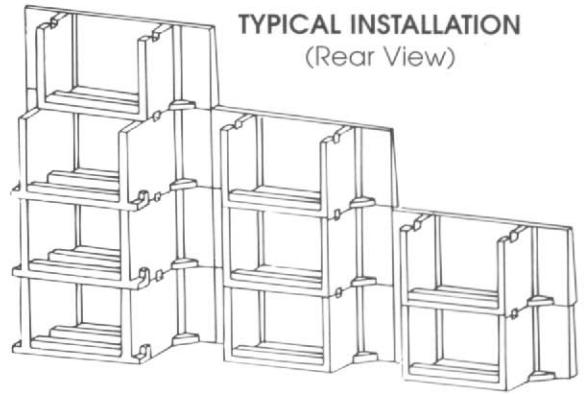

STRAIGHT WALL
(Plan View)

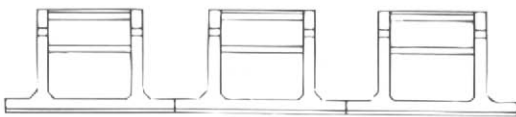

CURVED WALL
(Plan View)



FEATURES

- Low cost
- Simple installation
- Aesthetically pleasing
- Minimize cut depth
- All weather construction
- Large 40 sq.ft. per unit minimizes crane time
- Standard section in stock
- Quality precast concrete construction
- Geotextile reinforcing optional
- Advanced computer engineering
- US Patent, Trademark applied for

DIMENSIONS		CONCRETE WEIGHT	EARTH FILL	TOTAL WEIGHT	
10' x 4' x Depth		per piece	Volume	Concrete	
Piece Type	Feet	lbs.	per piece	and Earth	
			cu. yd.	lbs. per ft.	
WITHOUT EARTH BEAM					
A	FOUNDATION	6'	9,160	6.63	2,140
B	STANDARD	6'	7,720	6.96	2,100
C	FOUNDATION	4'	6,830	4.22	1,430
D	STANDARD	4'	5,890	4.44	1,410
WITH EARTH BEAM					
E	FOUNDATION	6'	9,420	6.56	2,930
F	STANDARD	6'	7,970	6.86	2,880
G	FOUNDATION	4'	7,080	4.15	1,780
H	STANDARD	4'	6,150	4.37	1,760

MINIMUM FILL DENSITY 112.5 LBS. PER CU.FT.

Each **Everwall®** is custom designed using special computer software to meet specific requirements and site conditions.

The retaining wall system **Everwall®** has been developed by Systems Evergreen AG from Switzerland. The Evergreen wall system has been extensively used throughout the world for over eighteen years.

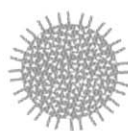
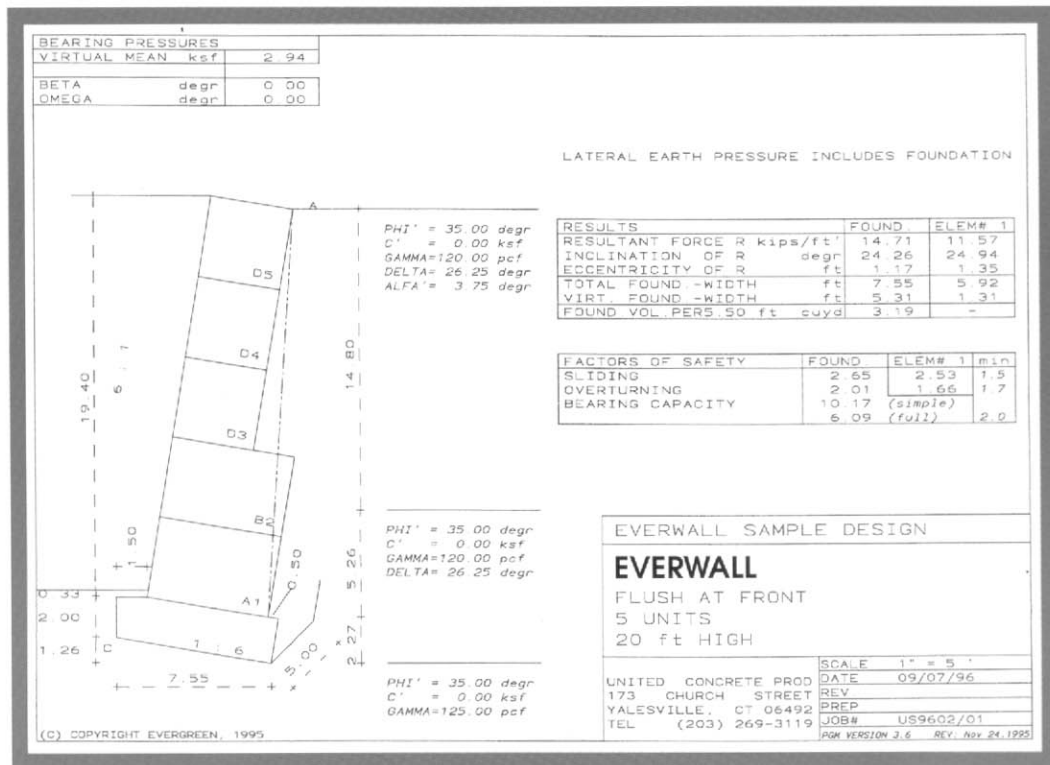

**UNITED
CONCRETE
PRODUCTS** Inc.

175 Church Street,
Yalesville, CT 06492
203.269.3119 Fax 203.265.4941