

8 OUTLET DISTRIBUTION BOX

D-BOX DESIGN SPECIFICATION
CONFORMS TO LATEST:
ASTM DESIGNATION C913

NOTES:

1. PIPE INLET AND OUTLET LOCATIONS HAVE POLYLOK PIPE SEALS.
2. CONCRETE COMPRESSIVE STRENGTH- 4000 PSI AT 28 DAYS.
3. METHOD OF MANUFACTURE: WET CAST.
4. SECTION IS MONOLITHIC.

WEIGHT CHART

PRODUCT	APPROX WEIGHT
8 OUTLET D-BOX	230 LBS.

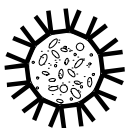
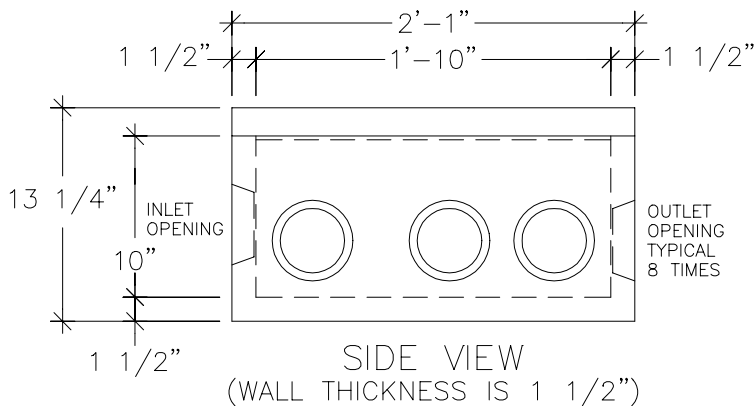
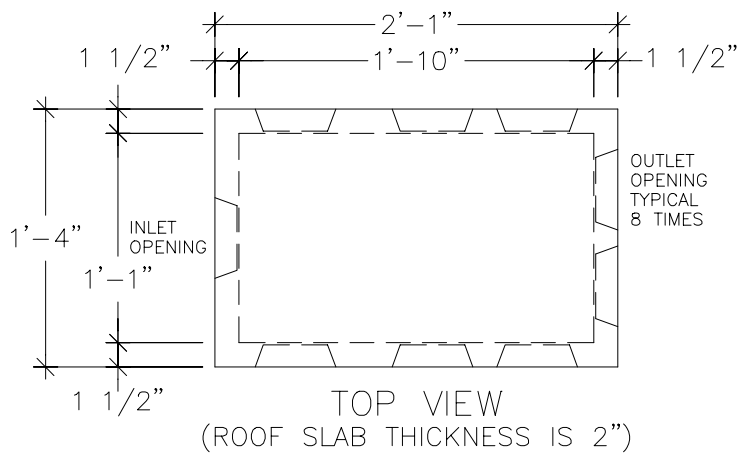
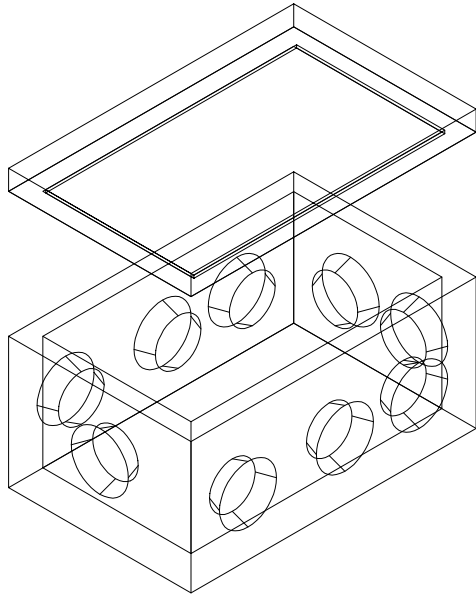

UNITED CONCRETE PRODUCTS INC.

173 CHURCH STREET
YALESVILLE, CT 06492

TEL. 800 234-3119
(203) 269-3119

FAX. (203) 265-4941