

SOUTH CENTRAL REGIONAL WATER AUTHORITY METER PIT

TANK DESIGN SPECIFICATIONS
CONFORMS TO LATEST:
ASTM DESIGNATION C913

NOTES:

1. JOINT SEALANT IS BUTYL RUBBER MASTIC TYPE SEAL THAT CONFORMS TO LATEST AASHTO SPECIFICATION M-198. MEETS FEDERAL SPECIFICATION SS-S-0021(210-A).
4. REINFORCING STEEL DEFORMED BARS CONFORM TO LATEST ASTM SPECIFICATION A615.
5. CONCRETE COMPRESSIVE STRENGTH- 4000 PSI AT 28 DAYS.
6. METHOD OF MANUFACTURE: WET CAST.
7. BASE SECTION IS MONOLITHIC.
8. THE CHAMBER IS DESIGNED FOR HS-20 LOADING w/18" OF SOIL COVER.

WEIGHT CHART

PRODUCT	APPROX WEIGHT
TANK	37400 LBS.

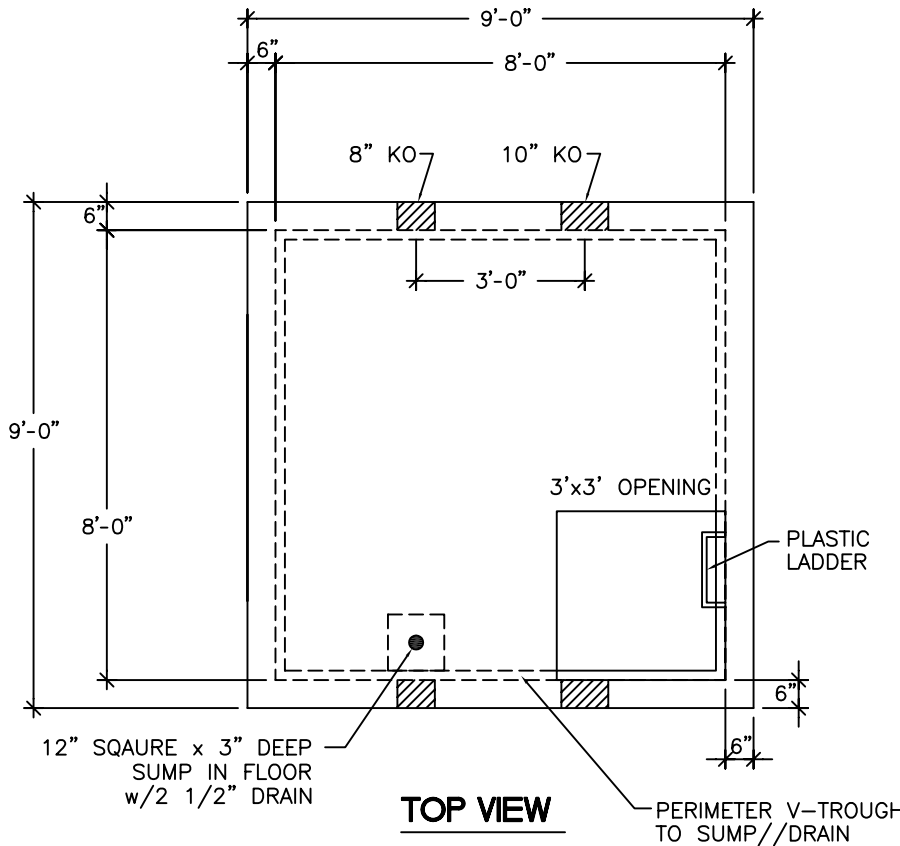

TOP VIEW

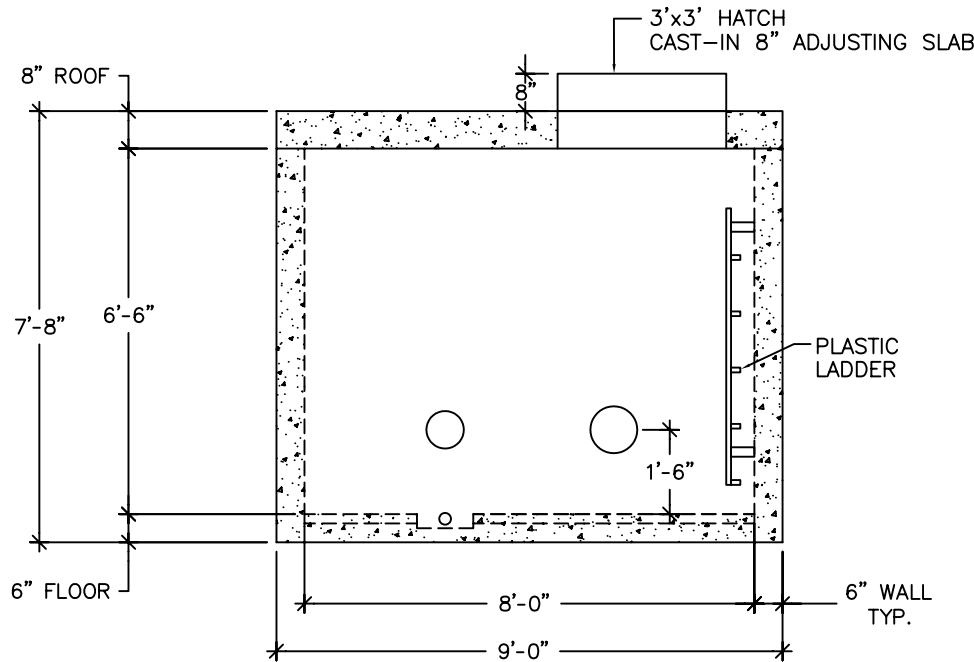

SIDE VIEW



UNITED CONCRETE PRODUCTS INC.

173 CHURCH STREET
YALESVILLE, CT 06492

TEL. 800 234-3119
(203) 269-3119

FAX. (203) 265-4941